

FICHE D'HOMOLOGATION HOMOLOGATION FORM



COMMISSION INTERNATIONALE
DE KARTING - FIA



SILENCIEUX D'ASPIRATION / INTAKE SILENCER

Constructeur	<i>Manufacturer</i>	KG sas
Marque	<i>Make</i>	KG
Modèle	<i>Model</i>	POWER 30
Catégories	<i>Categories</i>	KZ & KZ2
Durée de l'homologation	<i>Validity of the homologation</i>	3 ans / 3 years
Nombre de pages	<i>Number of pages</i>	5

La présente Fiche d'Homologation reproduit descriptions, illustrations et dimensions du silencieux d'aspiration au moment de l'homologation CIK-FIA et du test d'homologation.

This Homologation Form reproduces descriptions, illustrations and dimensions of the intake silencer at the moment of the CIK-FIA homologation and of the homologation test.



PHOTO DE L'AVANT /
PHOTO OF THE FRONT



PHOTO DE CÔTÉ /
PHOTO OF THE SIDE

**Signature et tampon de l'ASN /
Signature and stamp of the ASN**

**Signature et tampon de la CIK-FIA /
Signature and stamp of the CIK-FIA**



A	DESCRIPTIONS TECHNIQUES	A	TECHNICAL DESCRIPTIONS
	Volume en cm ³		Volume in cc
	3725 cm ³ +/-2%		3725 cm ³ +/-2%
	Matériau		Material
	POLYPROPYLENE		POLYPROPYLENE
	Nombre d'ouvertures d'admission d'air		Number of air intake openings
	«2		«2
	Longueur des conduits d'admission		Length of the inlet ducts
	98,1 mm +/-2% (≥98mm)		98,1 mm +/-2% (≥98mm)
	Diamètre des conduits d'admission		Diameter of the inlet ducts
	30 mm max.		30 mm max.
	Surface de l'élément filtrant intérieur		Surface of the internal filter
	227 cm ² +/-2% (≥200cm ²)		227 cm ² +/-2% (≥200cm ²)
	Epaisseur de l'élément filtrant		Thickness of the internal filter
	16 mm -10%		16 mm -10%

A1	DESSIN TECHNIQUE [dimensions d'encombrement – diamètre du (des) tube(s) d'admission – diamètre de la fixation au carburateur, sans tolérances]	A1	TECHNICAL DRAWING [main external dimensions – diameter of the inlet tube(s) – diameter of the fixation to the carburettor, without tolerances]
----	---	----	---

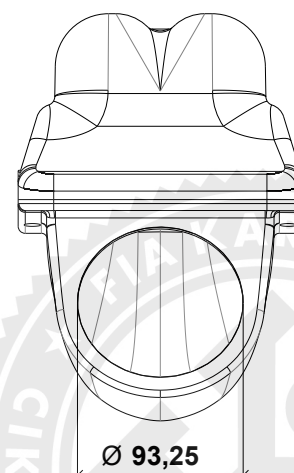
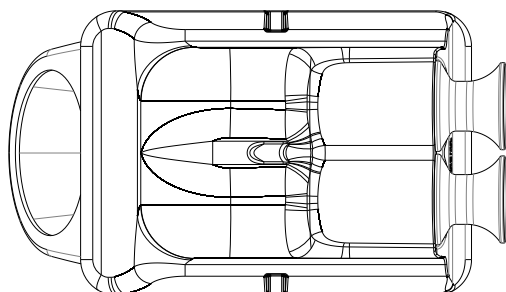
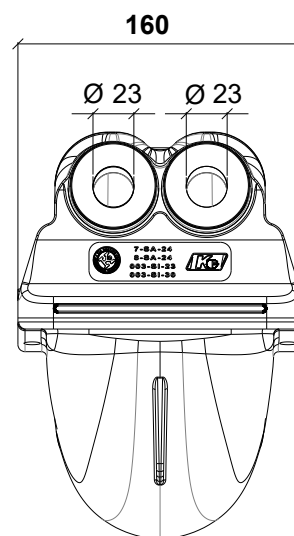
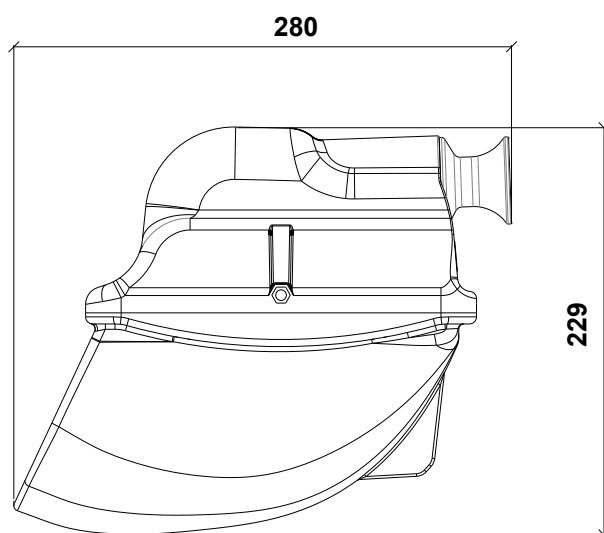

A2	DESSIN TECHNIQUE EXPLOSER	A2	EXPLODED TECHNICAL DRAWING
-----------	----------------------------------	-----------	-----------------------------------

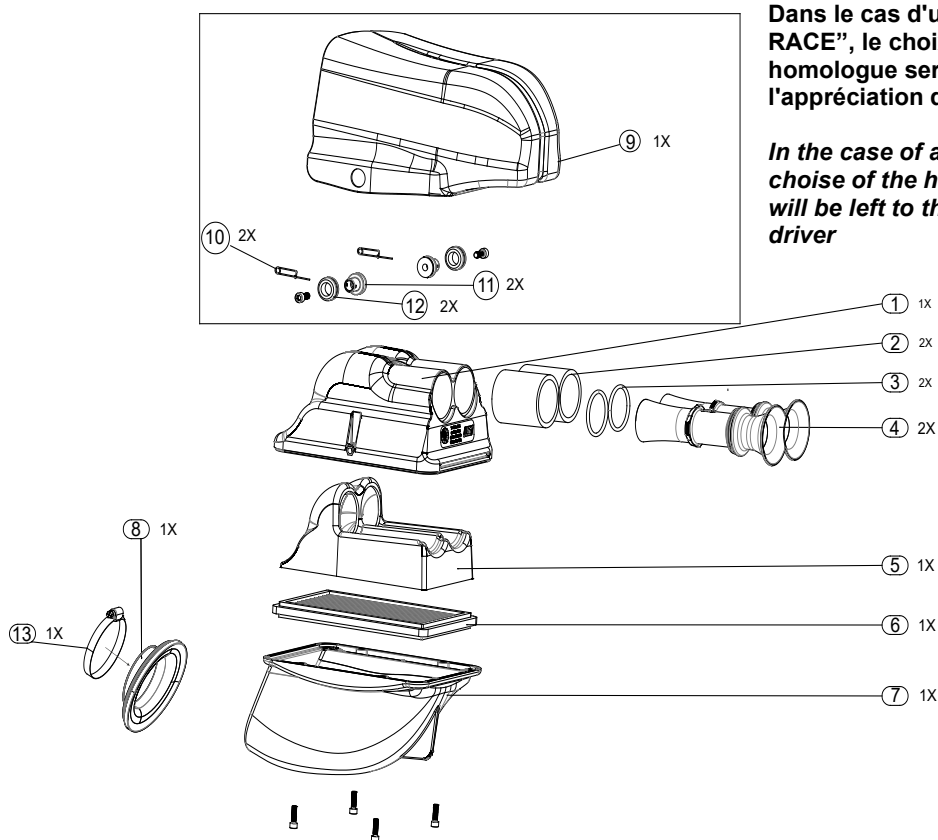

Le dessin technique explosé doit montrer : Eléments du silencieux, éléments acoustiques absorbants, éléments filtrants, tubes d'aspiration et manchon de fixation au carburateur.
The exploded technical drawing must show the following: parts of the silencer, noise-absorbing parts, filtering parts, suction tubes and carburettor clamping sleeve.

N°	DÉSIGNATION	DESIGNATION	Référence catalogue / Catalogue reference number
1	Coque supérieure	Upper case	RC.211.AG
2	Revetement insonorisation	Soundproofing coating	RC.220
3	Oring	Oring intake tube	RC.208
4	Tube démontable de boîte à air Ø 23mm	Intake tube Ø 23 mm	RC.207.30.NE
5	Silencieux interne	Absorbing element case	RC.209
6	Filtre	Panel filter	RC.241
7	Coque inférieure	Lower case	RC.237.AG
8	Collier serflex pour fixation de boîte à air	Air box rubber connector	RC.236
9	Kit de protection pluie	Rain cover kit	RC.215
10	Agrafe de sécurité	Safety clip	RC.217
11	Manchon	Bushing	RC.213
12	Connexion de protection de l'eau	Rubber washer for rain cover	RC.214
13	Serre-joint en métal	Metal screw clamp	RC.147
L'élément N. 1 peut être tourné à 180°		The element n. 1 can be rotated 180°	

A3	PHOTO DU MARQUAGE ET NUMÉRO D'HOMOLOGATION	A3	PHOTO OF MARKING AND HOMOLOGATION NUMBER
----	--	----	--



Le Marquage et le Numéro d'Homologation doivent rester clairement visibles en permanence. / The marking and the homologation number must remain clearly visible permanently.

A4	PHOTO DU FILTRANT	A4	PHOTO OF THE FILTER
----	-------------------	----	---------------------

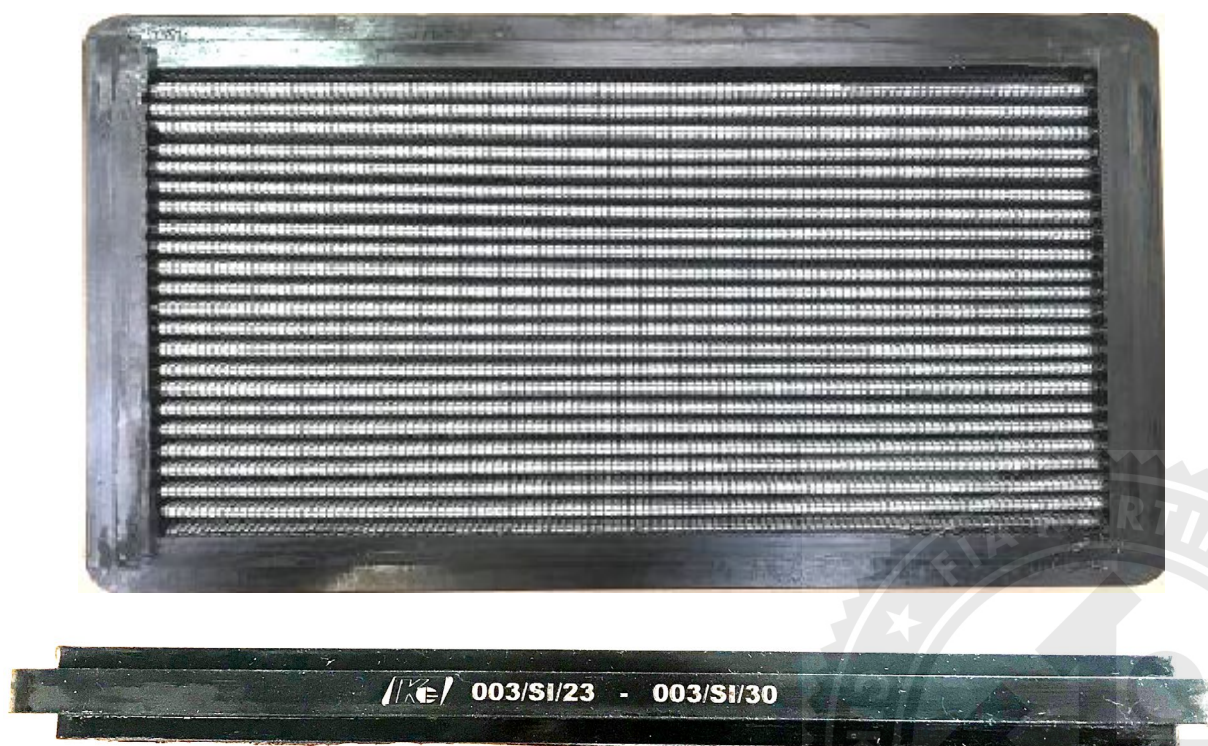

Photo du filtrant complet vu du haut et cote. / Photo of the filter from above and from the side.